



Part Number MET0000044

GLC Galvanised Steel Folding IBC (1000Ltr).

Bag in Box Technology.

Rental Only.

For the transport and storage of non Hazardous Liquids. Food Stuffs, Non Hazardous Chemical applications and more.....

Description

Galvanised Steel Folding IBC (1000 Ltr). Bag in Box Technology

7 degree sloped base for liquid products, compatible with 2" and 3" liquid Liners. Food Stuffs, Non Hazardous Chemical applications and more.....

Forklift, Pallet truck, Racking suitable.

H1200mm x L1200mm x W1000mm



Model	GLC
Part Number	MET0000044
Capacity	1000
Dimensions External (mm)	H:1200 x L:1200 x W:1000
Dimensions Folded (mm)	H:450 x L:1200 x W:1000
Tare Kg (from - to)	180 - 201
Gross Weight Kg (from - to)	1680 - 1701
Max S.G	1.5
Base Slope	7 deg
UN Packaging Group	N/A
Test Pressure	0
Max Working Pressure	0
Vaccum	0
Construction	Galvanised Mild Steel with plastic level window
<u>Transport and storage</u>	
Warehouse Store	
Stack Qty Full	4
Stack Qty Empty (Folded)	10
<u>40 ft Taut liner</u>	
Stack Qty Full	2
Stack Qty Empty (Folded)	5
<u>Shipping Container</u>	
Stack Qty Full	2



Stack Qty Empty (Folded)	5
---------------------------------	---

Construction

Heavy duty Galvanised steel construction, manufactured from heavy gauge steel for the most demanding environments.

Handling

Forklift truck and pallet truck. Optional fork-loop arrangements available.

Transport

The dimensions of H1200mm x L1200mm x W1000mm and a 7 degree slope make this unit ideally suited to product that flows easily.

Storage

Pallet Racking compatible
Self stacking

Advantages

The GLC Galvanised Steel foldable bag-in-box is a low cost rental option for the transport and storage of liquid products such as SCM, fruit juice, dairy products and cosmetics.

The GLC has a capacity of over 1000 litres, is built to last and has unrivalled strength.

Easy to assemble, fill and discharge.

Large outlets aid product discharge.

Metano Liquid Liners

2" and 3" cutter membrane and 2" and 3" butterfly valve liners. Available in 3 ply LLDPE, can be manufactured with intermediate barrier layers if required.

All Liners are manufactured by Metano to the highest standards in our BRC approved ISO validated clean room.

All Metano rental units are reusable and can be recycled at the end of life. Metano can offer a truly sustainable cradle to grave rental solution for all your liquid packaging needs.

Contact Metano Today for a rental Quote.

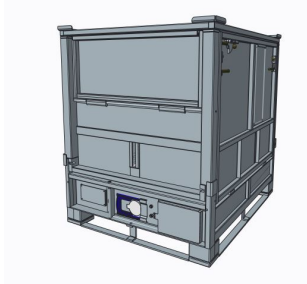

Full Perimeter Base & 2 inch Valve plate with stacking lugs
Comprises of
MET0000541 GLC Lid Complete with Stacking Lugs
MET0000532 GLC No1 Left Panel Complete (standard)
MET0000590 GLC Pallet Base (Bolted Type) Full Perimeter Base
MET0000533 GLC No2 Right Panel Complete (Standard)
MET0000534 GLC No3 Bottom Front Gate Panel Complete (standard)
MET0000542 GLC No 4 Back Panel Complete (Standard)
MET0000535 GLC No3 Top Half Drop Gate Panel Complete (Standard)
MET0000436 GLC 2" Stainless Steel Valve Plate c/w C Clip
MET0000321

MET0000561

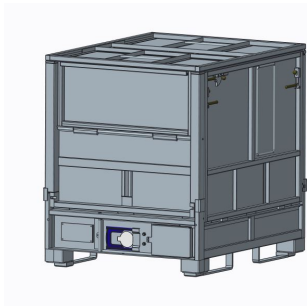

Bolted double long loop without stacking lugs
Comprises of
MET0000554 GLC Lid Complete without Stacking Lugs
MET0000597 GLC Pallet Base (Bolted Type) 2 x Long (left and right) Bolted Fork Loops on 1200 side
MET0000535 GLC No3 Top Half Drop Gate Panel Complete (Standard)
MET0000532 GLC No1 Left Panel Complete (standard)
MET0000533 GLC No2 Right Panel Complete (Standard)
MET0000534 GLC No3 Bottom Front Gate Panel Complete (standard)
MET0000542 GLC No 4 Back Panel Complete (Standard)
MET0000436 GLC 2" Stainless Steel Valve Plate c/w C Clip
MET0000321

MET0000560

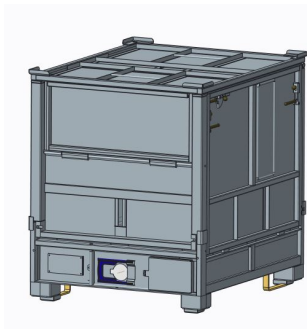

Single Welded Loop 2" valve plate with stacking lugs.
Comprises of
MET0000612 GLC Pallet Base (Welded Type) 1 x Short welded loop (right) on 1200 side
MET0000541 GLC Lid Complete with Stacking Lugs
MET0000535 GLC No3 Top Half Drop Gate Panel Complete (Standard)
MET0000532 GLC No1 Left Panel Complete (standard)
MET0000533 GLC No2 Right Panel Complete (Standard)
MET0000534 GLC No3 Bottom Front Gate Panel Complete (standard)
MET0000542 GLC No 4 Back Panel Complete (Standard)
MET0000612 GLC Pallet Base (Welded Type) 1 x Short welded loop (right) on 1200 side

MET0000614

Welded Short Double Loop with stacking lugs 2" Valve Plate
Comprises of
MET0000608 GLC Pallet Base (Welded Type) 2 x Short welded loops (left and right) on 1200 side
MET0000541 GLC Lid Complete with Stacking Lugs
MET0000535 GLC No3 Top Half Drop Gate Panel Complete (Standard)
MET0000532 GLC No1 Left Panel Complete (standard)

MET0000611

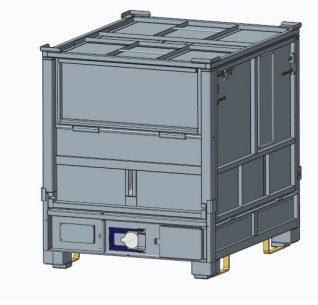

MET0000533 GLC No2 Right Panel Complete (Standard)
MET0000534 GLC No3 Bottom Front Gate Panel Complete (standard)
MET0000542 GLC No 4 Back Panel Complete (Standard)

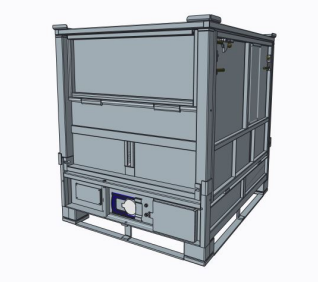

Full Perimeter Base 3 inch Valve Plate with stacking lugs
Comprises of
MET0000319 GLC 3" Stainless Steel Valve Plate c/w C Clip
MET0000323
MET0000541 GLC Lid Complete with Stacking Lugs
MET0000532 GLC No1 Left Panel Complete (standard)
MET0000590 GLC Pallet Base (Bolted Type) Full Perimeter Base
MET0000533 GLC No2 Right Panel Complete (Standard)
MET0000534 GLC No3 Bottom Front Gate Panel Complete (standard)
MET0000542 GLC No 4 Back Panel Complete (Standard)
MET0000535 GLC No3 Top Half Drop Gate Panel Complete (Standard)

MET0000563

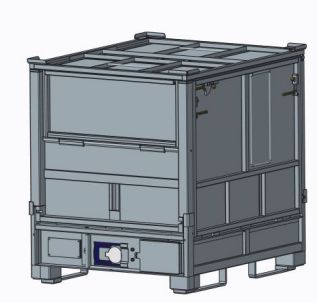

Bolted Double Long Loop & 2 inch Valve plate with stack lugs
Comprises of
MET0000597 GLC Pallet Base (Bolted Type) 2 x Long (left and right) Bolted Fork Loops on 1200 side
MET0000541 GLC Lid Complete with Stacking Lugs
MET0000535 GLC No3 Top Half Drop Gate Panel Complete (Standard)
MET0000532 GLC No1 Left Panel Complete (standard)
MET0000533 GLC No2 Right Panel Complete (Standard)
MET0000534 GLC No3 Bottom Front Gate Panel Complete (standard)
MET0000542 GLC No 4 Back Panel Complete (Standard)
MET0000436 GLC 2" Stainless Steel Valve Plate c/w C Clip
MET0000321

MET0000562

Bolted Double Short Loop, no stack lugs, doc holder-2" Valve plate,
Comprises of
MET0000436 GLC 2" Stainless Steel Valve Plate c/w C Clip
MET0000321
MET0000530 GLC Pallet Base (Bolted Type) 2 x Short (left and right) Bolted Fork Loops on 1200 side
MET0000554 GLC Lid Complete without Stacking Lugs
MET0000532 GLC No1 Left Panel Complete (standard)
MET0000533 GLC No2 Right Panel Complete (Standard)
MET0000534 GLC No3 Bottom Front Gate Panel Complete (standard)
MET0000536 Back Panel No 4 Complete with Document Holder
MET0000537 GLC No 3 Top Half Drop Gate Panel c/w Document

MET0000528

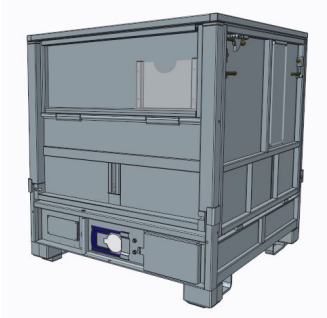

Holder

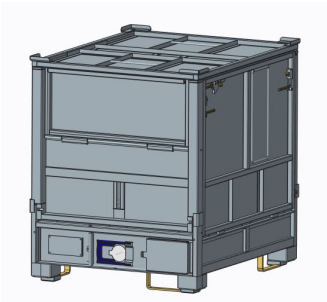

Single Welded Loop all sides with stacking lugs 2" Valve Plate
 Comprises of
 MET0000541 GLC Lid Complete with Stacking Lugs
 MET0000535 GLC No3 Top Half Drop Gate Panel Complete
 (Standard)
 MET0000532 GLC No1 Left Panel Complete (standard)
 MET0000533 GLC No2 Right Panel Complete (Standard)
 MET0000534 GLC No3 Bottom Front Gate Panel Complete
 (standard)
 MET0000542 GLC No 4 Back Panel Complete (Standard)
 MET0000613 GLC Pallet Base (Welded Type) 1 x Short welded
 loop (right) on All sides

MET0000615

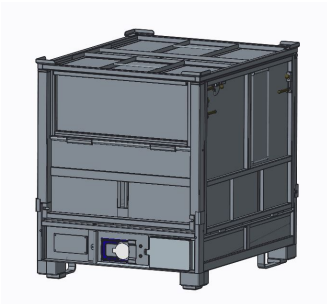

Single Short Bolted Loop with stacking lugs 2 inch Valve Plate
 Comprises of
 MET0000541 GLC Lid Complete with Stacking Lugs
 MET0000535 GLC No3 Top Half Drop Gate Panel Complete
 (Standard)
 MET0000532 GLC No1 Left Panel Complete (standard)
 MET0000533 GLC No2 Right Panel Complete (Standard)
 MET0000534 GLC No3 Bottom Front Gate Panel Complete
 (standard)
 MET0000542 GLC No 4 Back Panel Complete (Standard)
 MET0000436 GLC 2" Stainless Steel Valve Plate c/w C Clip
 MET0000321
 MET0000731 GLC Pallet Base (Bolted Type) 1 x Short (right)
 Bolted Fork Loop on 1200 side

MET0000705